

POS.	CODICE MODELLO:	DESCRIZIONE	DESCRIPTION	DESCRIPTION	BESCHREIBUNG	Q.TY
	600 - - -					
1	5010	Optional mot. pompa scarico 190W	Optional discharge pump motor,190W	Option moteur pompe vidange 190W	Opt. Motor für Pumpe vom Abfluß 190W	1
2	1320	Tubo di scarico ø32 mm	Discharge pipe, ø32 mm	Tuyau de vidange ø32 mm	Abflußschlauch ø32 mm	1
3	1367	Dado per codolo di scarico da 1" 1/2G	Nut for discharge shaft,1" 1/2G	Ecrou pour extrémité tuyau de vidange de 1" 1/2G	Mutterschraube für Endstück vom Abfluß 1" 1/2G Zoll	1
4	600720	Tubo ø30 lavaggio sup.	Upper wash pipe, ø30 mm	Tuyau d.ø30 lavage sup.	Lauch ø30 mm oberes Spülen	1
5	600705	Manicotto ø32 raccordo inferiore	Lower joint rubber hose, ø32 mm	Manchon d.ø32 raccord inf.	Muffe ø32 mm unterer Anschluß	1
6	1215	Peso per tubetto aspirazione	Weight for intake tube	Poids pour petit tuyau aspiration	Gewicht für Ansaugschlauch	1
7	1218	Filtro per tubetto aspirazione	Filter for intake tube	Filtre pour petit tuyau aspiration	Filter für Ansaugschlauch	1
8	520	Fascietta inox 21-44	Stainless steel band, 21-44	Collier inox 21-44	Schelle aus Edelstahl 21-44	1
9	800750	Collettore inox lavaggio inferiore	Lower wash stainless steelmanifold	Collecteur inox lavage inférieur	Sammler aus Edelstahl unteres Spülen	1
10	600420	Boiler inox	Stainless steel boiler	Chauffe-eau inox	Boiler aus Edelstahl	1
11	530	Fascetta inox 40-65	Stainless steel band, 40-65	Collier inox 40-65	Schelle aus Edelstahl 40-65	4
12	800706	Manicotto ø50 raccordo inf.	Coupling for lower joint, dø50 mm	Manchon diam. 50 raccord inf.	Muffe ø50 unterer Anschluß	1
13	500	Fascetta inox 10-20	Stainless steel band, 10-20	Collier inox 10-20	Schelle aus Edelstahl 10-20	6
14	103425	Resistenza boiler 3300 W	Boiler heater, 3300 W	Résistance chauffe-eau 3300 W	Heizschlange Boiler 3300 W	1
15	103415	Guarnizione or resist. con flangia	OR resistor gasket with flange	Bague torique résistance avec bride	O-Ring-Dichtung für Heizsch.mit Flansh	1
16	1220	Dosatore detergente elett. regolabile	Adjustable electric detergent doser	Doseur détergent électrique réglable	Elektr., einstellbarer Dos. für Spülmittel	1
17	1212	Tubetto in santoprene	Santoprene tube	Petit tuyau en santoprène	Kleiner Schlauch aus Santopren	1
18	1200	Dosatore di brillantante	Rinse doser	Doseur de liquide rinçage	Dosierer für Klarspüler	1
19	1380	Tubo gomma 10-19 90°C al mt	Rubber hose, 10-19 90°C per metre	Tuyau en caoutch .10-19 90°C au mètre	Gummischlauch 10-19 90°C, pro lfd. M	1
20	103370	Elettrovalvola	Solenoid valve	Electrovanne	Elektroventil	1
21	1305	Tubo carico acqua da 2.0 mt	Water entry pipe, 2.0 m	Tuyau de remplissage eau de 2 m	Wasseransaugschlauch, 2 m lang	1
22	600700	Manicotto ingresso pompa	Pump entry rubber hose	Manchon entrée pompe	Muffe Pumpeneingang	1
23	6400	Motore pompa lavaggio HP 0,75	Wash pump motor, 0.75 HP	Moteur pompe lavage HP 0,75	Motor Spülpumpe 0,75 PS	1
24	6410	Chiocciola motore pompa	Pump motor volute	Vis sans fin moteur pompe	Spiralgehäuse Pumpenmotor	1
25	6411	Girante pompa	Pump rotor	Roue pompe	Lauftrad Pumpe	1
26	6014	Guarnizione tenuta rotante	Rotary sealing gasket	Joint d'étanchéité rotatif	Dichtung Lauftrad	1
27	6013	Guarnizione tenuta ceramica	Ceramic sealing gasket	Joint d'étanchéité céramique	Keramikdichtung	1
28	6412	Guarnizione or per chiocciola pompa	Pump volute OR gasket	Bague torique pour vis sans fin pompe	O-Ring-Dichtung für Spiralgeh. Pumpe	1
29	6415	Condensatore motore	Motor capacitor	Condensateur moteur	Kondensator vom Motor	1
30	103400	Resistenza vasca 2000 W	Tank resistor, 2000W	Résistance cuve 2000 W	Heizschlange Becken 2000 W	2
31	1365	Codolo curvo scarico da 40 mm	Curved discharge shaft, 40 mm	Extrémité coude vidange de 40mm	Gebogenes Endstück . Abfluß 40 mm	1
32	1362	Raccordo polietilene	Joint	Raccord	Anschlub	1
33	1363	Guarnizione esterna piana	Gasket for discharge drain	Joint pour siphon vidange	Dichtung für Ablauf vom Abfluß	1
34	1410	Tubetto 6x4 mm trasparente	Transparent tube, 6x4 mm	Petit tuyau 6x4 mm transparent	Kleiner transparen. Schlauch 6x4 mm	1
35	1211	Raccordo completo iniettore vasca	Complete joint for tank injector	Raccord complet injecteur cuve	Kompletter Anschluß	1
36	600725	Tubo di gomma 90°C con raccordo da 3/4G	Rubber pipe 90°C with 3/4G joint	Tuyau en caoutchouc 90°C avec raccord de 3/4G	Einspritzdüse Becken Gummisch. 90° mit Anschluß 3/4G Zoll	1
37	1361	Guarnizione or interna piletta inox	OR gasket	Bague torique	O-Ring-Dichtungl	1
38	1360	Piletta inox da 1" 3/4G	Inox drain, 1"fiG	Siphon Inox de 1" 1/2G	Inoxablauf 1"fiG Zoll	1
39	800101	Tubo troppo pieno inox ø40	Stainless steel "too full" pipe ø40	Tuyau trop-plein inox ø40	Überlaufrohr aus Edelstahl ø40	1
40	3250	Filtro inox	Stainless steel filter	Filtre inox	Filter aus Edelstahl	1
41	3280	Trappola d'aria	Air trap	Prise d'air	Luftfalle	2
42	1366	Guarnizione codolo	Gasket	Joint	Dichtung	1
43	6413	Flangia motore pompa HP 0,75	flange wash pump 0,75 HP	Bride moteur pompe	Flansch Pumpenmotor	

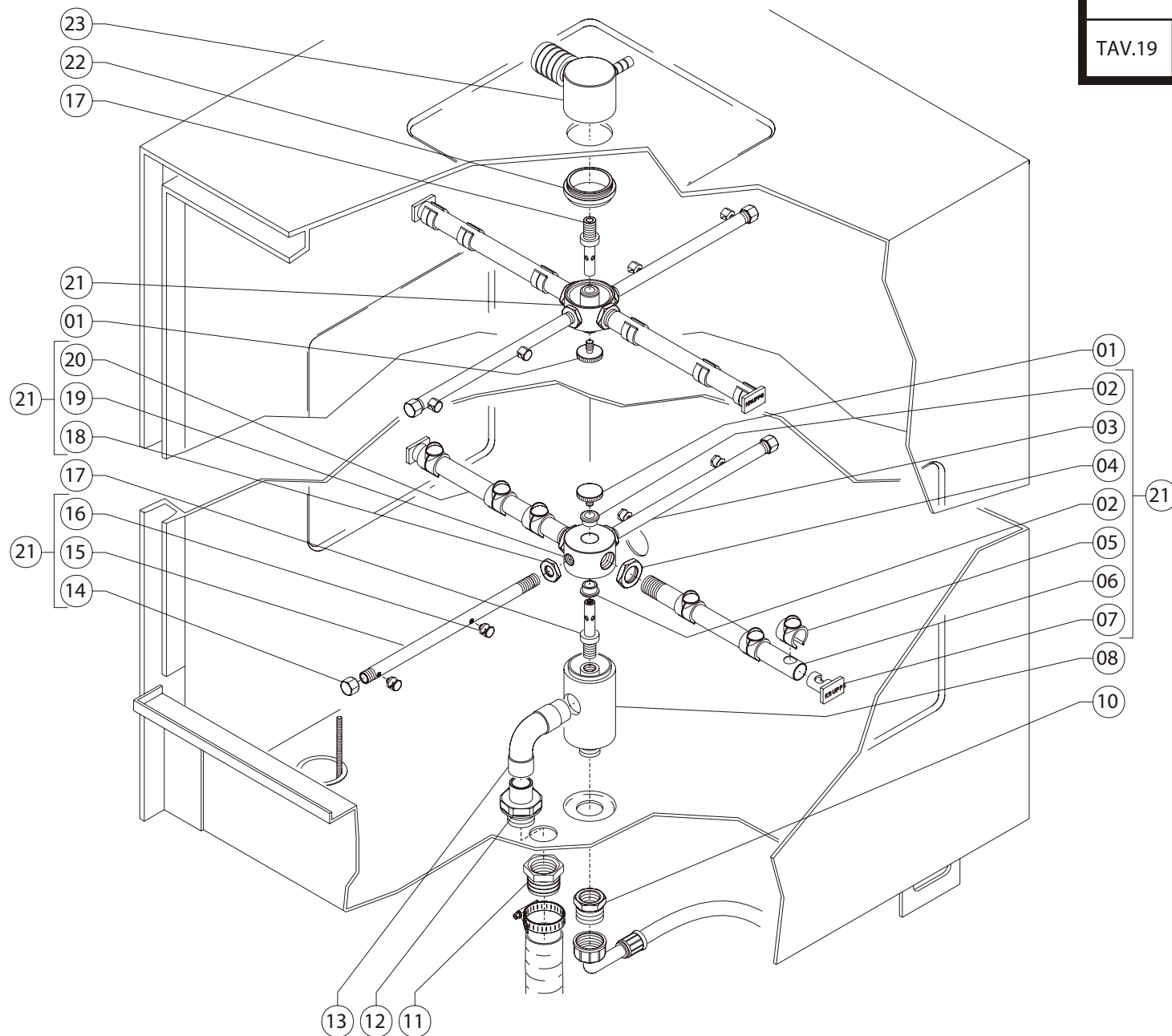

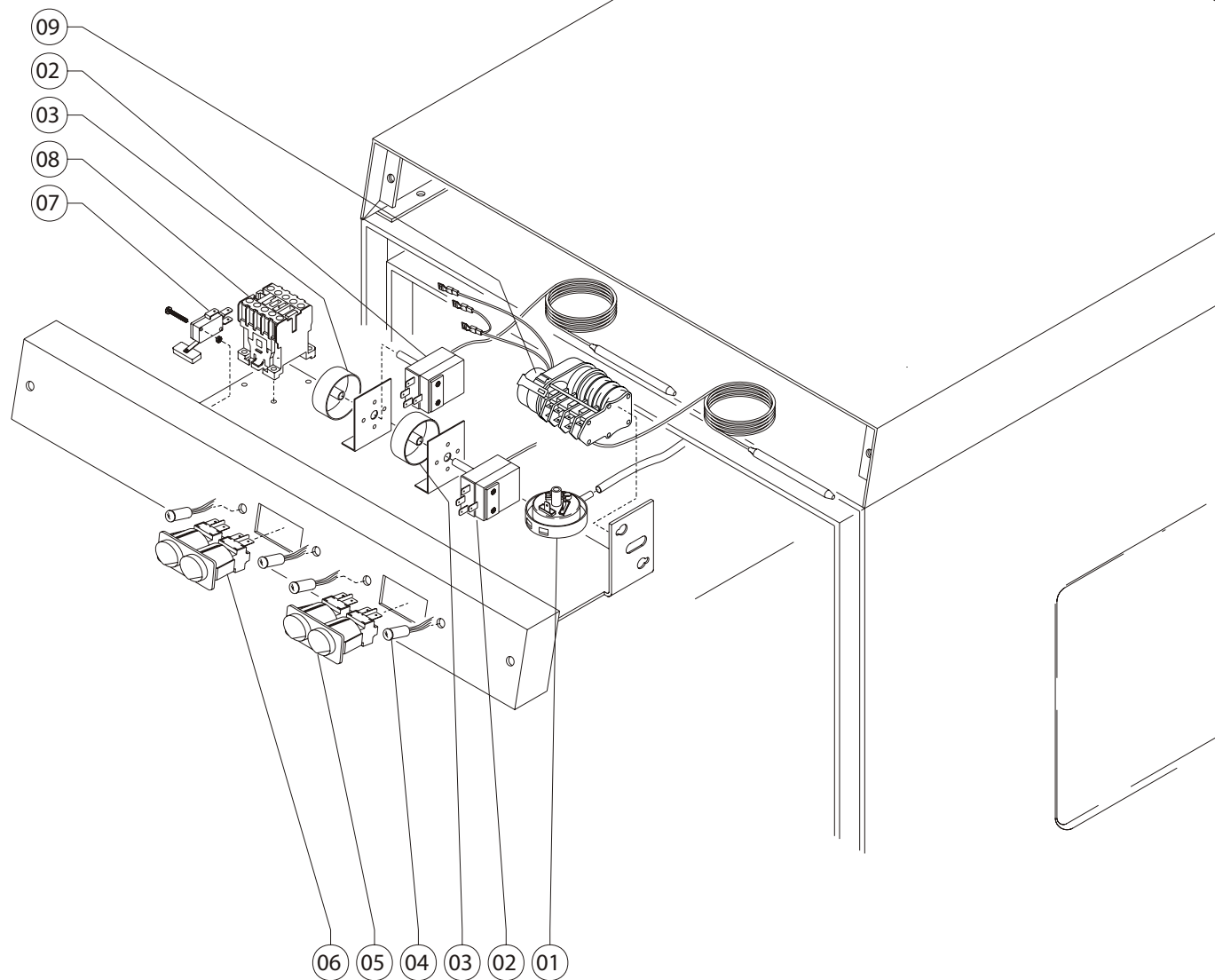

KORAL 600

TAV.21

CESTELLI

01

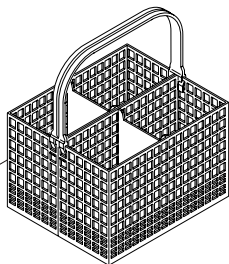

02

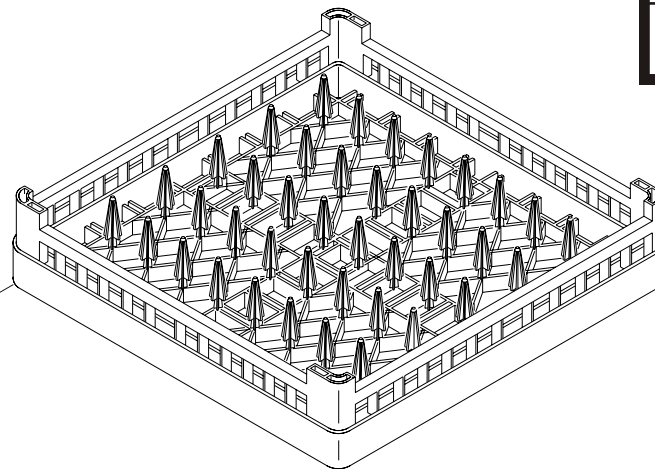

03

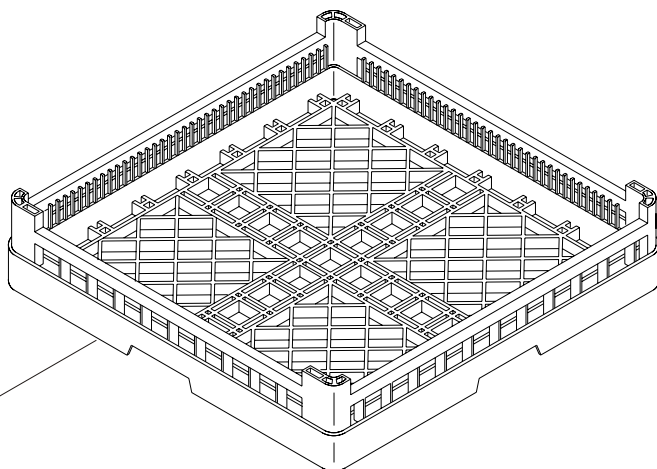

04

